



Personal Power Pack Jump Starters

SJS05G2

USER MANUAL

12 V, 500 Amp, 12,800 mAh (47.36 Wh)

Jump start MOST vehicles up to:

3 L DIESEL (3000 cc)

6 L PETROL (6000 cc)

Power 12V DC appliances up to 180 W (15 A)



SMART JUMP STARTERS PTY LTD

www.smartjumpstarters.com.au

Australian Owned and Operated

This product offers the latest innovative lithium polymer battery technology in portable personal power devices. Extensive testing procedures and inbuilt protection systems ensure that this product is easy to use and will give you years of service life.

Please take the time to read this manual so that you can correctly use the Personal Power Pack Jump Starter and all of its features.

IMPORTANT

All PERSONAL POWER PACK JUMP STARTERS are designed to be used as an EMERGENCY JUMP STARTER and a PORTABLE POWER SUPPLY to enable charging of most digital devices. They are capable of jump starting most vehicles with flat batteries. They are NOT a vehicle battery charger. They will not rectify existing starting system problems in vehicles.

THEY ARE NOT TO BE USED OR ATTEMPTED TO BE USED AS A PERMANENT POWER SUPPLY FOR ANY VEHICLE.

POWER PACK FEATURES

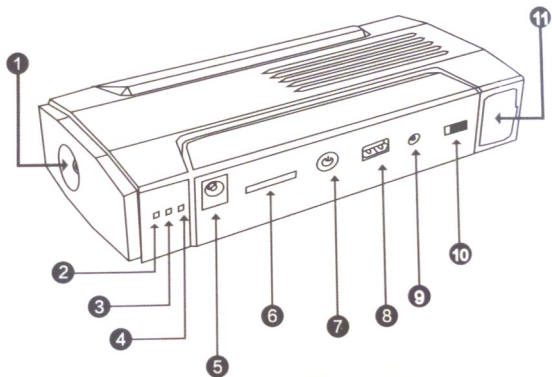

- | | |
|---|--|
| 1. LED Flash Light | 2. 19 V Voltage Output Indicator light |
| 3. 16 V Voltage Output Indicator Light | 4. 12 V Voltage Output Indicator Light |
| 5. Multi-Volt Charge Port
(12 V, 2A/16 V, 3.5 A/19 V, 3.5 A) | 6. Power Pack Charge Indicator Light |
| 7. Mode Switch | 8. USB 5 V, 2 A Output Port |
| 9. 15V, 1A Charging Input Port | 10. Master Switch |
| 11. 12 V Jump Start Port | |

ACCESSORIES

240 V AC Battery Charger

A



12 V DC Cigarette Lighter Battery Charger

B



Jumper Leads

C



USB Cable & Adaptors

D



12 V, 16 V, 19 V Cable & Adaptors

E



CHARGING THE POWER PACK

Before initial use, please make sure the power pack is fully charged. It can be charged using either the 240 V AC battery charger (A) or the 12 V DC cigarette lighter battery charger (B).

Plug the 240 V charger (A) into power outlet, then plug cable into the charging input port (9). Turn power on. Push the mode switch (7) once. The four blue LED indicator lights (6) will light up and start flashing to indicate that charging has commenced. To check charge status push the mode switch (7) once. The four blue LED indicator lights will remain solid blue when fully charged. Turn power off, remove the charger from the power pack and ensure the master switch (10) is in the "OFF" position.

To charge the power pack in the car, use the same process as above using the cigarette lighter charger (B) in the car's 12 V power outlet socket.

Initial charge time: Approximately 3 hours. Subsequent recharging time will depend on the residual charge in the power pack.

The power pack has inbuilt overcharge protection, however it is recommended that you do not leave the power pack permanently on charge. Regular periodic recharging of the power pack is recommended to enhance the lithium polymer battery life, and it should be charged at least once within a twelve month period. The lithium polymer battery has no memory effect.

The lithium polymer battery inside the power pack has a low self-discharge rate. When fully charged, the power pack will self-discharge by approximately 10-15% over a 6 to 8 month period when the master switch is in the 'OFF' position. This can be affected by the ambient temperature of the storage location. Regular charging is recommended.

WARNING:

Use only the battery chargers supplied with this product to charge or recharge the power pack. The use of any other battery charger could cause catastrophic battery damage or serious injury and will void any warranty.



INSTRUCTIONS FOR JUMP STARTING A VEHICLE USING 'JUMP START SAFE' JUMPER LEADS

REFER TO LED INDICATOR GUIDE ON THE JUMPER LEADS

1. Plug the jumper leads (C) into the jump port (11) of the power pack. The LED light on the jumper leads RCP unit will be solid red.
2. Identify the positive and negative battery terminals of the vehicle battery. Connect the red jumper clamp to the positive terminal and the black jumper clamp to the negative terminal. The LED light on the RCP unit of the jumper leads will turn solid green when connected correctly.
3. Start the vehicle - only when the LED light is solid green. **DO NOT CONTINUOUSLY CRANK THE VEHICLE.** Disconnect the jumper leads from the vehicle battery as soon as the vehicle is started.
4. Disconnect the jumper leads from the power pack and store in its case.



LED LIGHT IDENTIFICATION CODES

STANDBY: SOLID RED LED - Jumper leads are connected to power pack and in SHORT CIRCUIT PROTECTION MODE.

BATTERY DETECTION: SOLID RED LED - Jumper clamps connected to battery but vehicle battery has less than 6V (NO OUTPUT). RECHARGE/REPLACE VEHICLE BATTERY.

CORRECT CONNECTION: SOLID GREEN LED - Jumper clamps are connected correctly to the vehicle battery terminals. READY TO JUMP START (1 minute time-out).

INCORRECT CONNECTION: FAST RED FLASH LED - Jumper leads are not connected to the vehicle battery terminals correctly (NO OUTPUT).

OVER TEMPERATURE: SLOW GREEN FLASH LED - Jumper leads are over heating from continuous cranking or overload. NO OUTPUT until leads cool down.

LOW VOLTAGE: FAST GREEN FLASH LED - Power pack voltage is too low for jump starting attempt. Fully charge the power pack (NO OUTPUT).

VOLTAGE DIFFERENTIAL: Alternate RED/GREEN FLASH LED - Vehicle battery voltage is HIGHER than power pack (NO OUTPUT).

REVERSE CURRENT: Alternate RED/GREEN FLASH LED - Vehicle engine has started and is running (NO OUTPUT). Disconnect power pack from vehicle battery IMMEDIATELY.

CHARGING DIGITAL DEVICES

Check the charging requirement voltage and current for your device.

Check the power pack's charge status by sliding the master switch (10) to the 'ON' position and pressing the mode switch (7) once. The blue LED indicator lights and the USB port will light up.

The power pack has two output ports:

- USB 5 V, 2 A output port (8)
- 12 V, 2 A/16 V, 3.5 A/19 V, 3.5 A output port (5)

USB 5V 2 AMP CHARGING PORT

Plug the USB cable (D) into the USB charge port (8), select the USB adaptor (D) to suit your device and plug it in to your device. Your device will start charging immediately.

12 V, 2 A/16 V, 3.5 A/19 V, 3.5 A CHARGING PORT

Check the charging requirement voltage and current for your device. Push the mode switch (7) in sequence to select between 12 V charging (4), 16 V charging (3) and 19 V charging (2). Plug the output cable (E) to the 12 V/16 V/19 V outlet port (5). Select the adaptor to suit the charge port of your device and plug it in to your device. Your device will start charging immediately.

Only use the USB cable and adaptors supplied with your Smart Jump Start Charger.

It is NOT possible to charge digital devices whilst the power pack is being charged. This is to protect the battery from possible damage.



LED FLASHLIGHT

The LED flashlight has 3 modes. Full, S.O.S. and emergency flash, operated in sequence.

1. Slide the master switch (10) to the 'ON' position.
2. Hold down the mode switch (7) for 2 seconds. The LED flashlight will turn on in 'Full' mode.
3. Press the mode switch (7) once. The LED flashlight will change to 'S.O.S.' mode.
4. Press the mode switch (7) once and the LED flashlight will change to 'Emergency Flash' mode.
5. Press the mode switch (7) once again and the LED flashlight will turn off.
6. Slide the master switch (10) to the 'OFF' position.



RESETTING THE POWER PACK

Your Personal Power Pack Jump Starter has many inbuilt protection features for your safety. Should any of the functions stop working, this indicates that the power pack has detected some kind of operational error and has automatically shut down. Eg., in an overload situation.

To reset the power pack, simply connect either of the battery chargers (A) or (B) to the power pack charge port (7) and place on charge. Leave the power pack on charge for approximately 20 seconds and the power pack will be reset.

STORAGE AND MAINTENANCE

Please store your Personal Power Pack Jump Starter in a dry location away from moisture.

Do not use solvents or detergents of any kind to clean the device. Use a clean dry rag to wipe clean.

Regularly charging the power pack is recommended to optimise battery life.

Treat the power pack with care. Dropping the device can cause damage.

SPARE PARTS:

- 240 V AC / 15 V DC battery charger
- 12 V - 15 V DC car cigarette lighter charger
- 'Jump Start Safe' jumper leads
- USB 4 in 1 cable
- 12 V/16 V/19 V cable and adaptors

Please contact your local distributor for spare parts and accessories. Full details of available parts and accessories can be found on our website.

TECHNICAL SPECIFICATIONS:

Size: L 165 mm x W 79 mm x H 40 mm

Weight: 495 g (power pack only)

Battery: Lithium Polymer 12 800 mAh (8 A, 47.36 Wh)

Output: Jump port - 12 V DC, 1 x USB output port - 5 V DC, 1 A,
1 x multi-volt 12 V, 2 A/16 V 3.5A/19 V 3.5 A DC output port

Start Current: 300 A with 500 A peak

Charging: AS approved 240 V AC/15 V DC charger, 12 V - 15 V DC 800 mA car cigarette lighter charger

Charge Time: Initial charge 3 hrs

Charge Cycles: Up to 2 000

Holding charge: Self-discharge rate of approximately 10-15% over 6-8 months (when not in use and stored with master switch in 'OFF' position). May vary according to storage ambient temperatures.

Protection and Safety: Inbuilt reverse current, overload, short circuit, surge, overcharge, over-discharge, overheat, voltage differential, short-circuit protection. Enclosed Terminals.

LED Flashlight: 3 modes — Full, S.O.S., Emergency Flash.

Operating Temperature Range: Minus 20 degrees Celsius to plus 60 degrees Celsius ambient.

WARRANTY

All SJS Personal Power Pack Jump Starters are covered by a 12 month warranty against manufacturing faults.

If any part is suspected of being faulty, the entire kit with all of its components must be returned to the place of purchase and accompanied with proof of purchase so that it can be returned to Smart Jump Starters Pty Ltd for testing. If found to be faulty, the part will be replaced.

Smart Jump Starters Pty Ltd will not be liable for any freight charges as part of a warranty claim.

Smart Jump Starters Pty Ltd will not be liable for any consequential damage in the unlikely event this should occur.

Warranty Exclusions:

- Power packs or components are not covered by warranty if they have been misused, dropped onto a hard surface, exposed to water or damaged in any way by using the device outside of its design parameters or not in accordance with instructions.
- Jumper leads are not covered by warranty if the 'Reverse Current Protection' device is blown. The reverse current protection device is a sacrificial device designed to protect the power pack. If this has occurred, you will need to purchase a replacement set of jumper leads at your own cost.
- Power packs are not covered by warranty if the power pack casing has been opened and the seals are broken. Do not attempt to open the power pack case under any circumstances. Doing so could lead to serious injury.

For technical advice, please contact SJS directly:



Smart Jump Starters Pty Ltd
1/13 Commerce Avenue
Warana QLD 4575
AUSTRALIA
E: sales@autoglobe.com.au
Website: www.smartjumpstarters.com.au